

Tel: (011) 805-5002  
 Fax: (011) 805-5033

Postal Address:  
 PO Box 7861  
 Halfway House, 1685

# The AAAMSA Performance Test Certificate



**NOT TRANSFERABLE**

**Section A: Particulars of Applicant**

**Applicant:**  
 Primador  
 P O Box 12172  
 CENTRAHIL  
 6006

**Certificate  
 Number**  
  
**D0715**

**Section B: Description of sample submitted for testing**

**AAAMSA Class Designation:**  
 PTH (A3)

**Applicants' Drawing Reference:**  
 Ref: W01

**Product**  
 30.5 Window

**Overall Dimensions:**  
 1790mm w x 1190mm h

**Glass Type:**

**Glass Thickness:**  
 4mm clear float

**Glazing Gaskets:**  
 H Gasket H4 / VP300FG - H20

**Weather Seals:**  
 Bubble seal / H Gasket BS 6750C

**Hardware:**  
 PT Euroline Handle

**Joint Sealant:**  
 Dow Corning 794

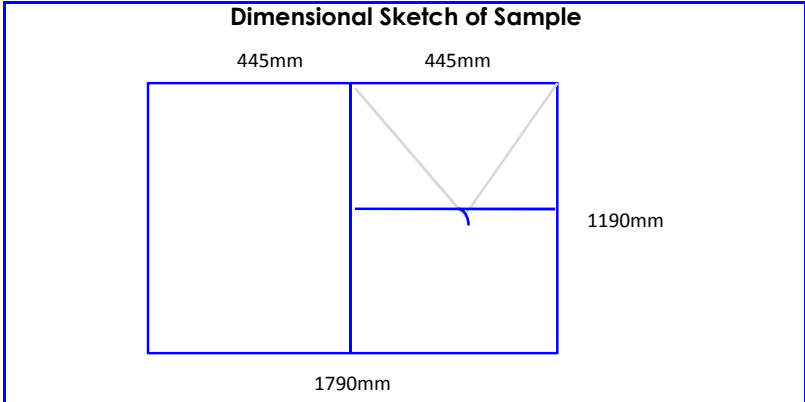

**Comments by Testing Authority**

~ No excessive silicone detected  
 ~ 1 Handle on sash  
 ~ Transom - 30mm  
 ~ Mullion - 70mm

**Section C: Testing**

**NOT TRANSFERABLE**

Performance Test	Test Conditions	Measured Result	Allowed Result
1. <b>Air Infiltration</b>	75 Pa	0.91 l/sec/m <sup>2</sup>	1.02 l/sec/m <sup>2</sup>
2. <b>Positive Pressure</b>	2000 Pa	1.995 mm	6.80 mm
3. <b>Negative Pressure</b>	2000 Pa	2.065 mm	6.80 mm
4. <b>Water Penetration</b>	400 Pa	No Leaks	No Leaks
5. <b>Structural Pressure</b>	3000 Pa	No permanent deformation	No Permanent deformation
6. <b>Operating Forces:</b>			
<b>To start movement</b>		50N	≥80N
<b>To sustain Movement</b>			

**Section C: Testing**

**Testing Authority:**  
**(Stamp)** Nelson Mandela Metropolitan  
 University (NMMU)  
 Private Bag X6011  
 Port Elizabeth, 6000

Validated by AAAMSA:  
**(Stamp)**

**Date of issue:** 11 June 2009

**Date of Validation:** 22 June 2009

**Signed:**

**Signed:**

**Designation:** Dr. F Geminiani - Testing Officer

**Designation:** EXECUTIVE DIRECTOR

## **PERFORMANCE TEST CERTIFICATE**

The performance test certificate is issued to members upon the successful testing of a product. The Performance Test Certificate is subject to the following conditions:

### **1. Sample**

The sample together with three (3) sets of full sized details shall be provided by the applicant to the testing authority without charge. After testing, one set of full size details shall be retained by the applicant and one set by AAAMSA in their original form.

### **2. Test Results**

The Test Results recorded in Section C hereof are accepted by the applicant as being applicable and restricted only to the sample and the testing thereof under the standard laboratory testing conditions and procedures of the testing authority, and no other product or unit apart from the sample itself or said testing conditions or procedures are to be implied

### **3. Extended Applicability**

The Performance Test Certificate applies equally to product of the same nature and function as that tested which products shall be identical in construction and configuration to the test sample, save only that the overall sizes recorded in the section B of the Certificate and the size of any ventilator, or subunit may be reduced.

### **4. Testing Authority**

The testing authority shall not be responsible or liable to the applicant for any loss or damage of whatsoever nature and howsoever arising in any way connected with or consequent upon the test carried out or the report furnished which shall be at the risk of the applicant. The applicant hereby indemnifies the testing authority and holds it harmless against any claims as herein contemplated by any third party.

### **5. AAAMSA**

5.1 The applicant hereby indemnifies the Association of Architectural Aluminium Manufacturers of South Africa (AAAMSA) and holds it harmless against any claims as herein contemplated by any third party.

5.2 This test certificate is not transferable to any third party.